

# *30 kW EV Charger with 82 kWh Battery Model EVPC3082*

## *Operation Manual*



MNL223

**READ THIS MANUAL CAREFULLY**

**SAVE ALL INSTRUCTIONS**

**INSTRUCTIONS IMPORTANTES CONCERNANT LA SÉCURITÉ**

**CONSERVER CES INSTRUCTIONS**

This manual contains important information regarding Power Innovations International products or processes listed on the title page. Please read all instructions carefully before assembling, installing, or operating equipment. Keep this manual handy for easy reference.

This manual may accompany other instructional guides or manuals for standard installation and operations of the supported products. Please contact Power Innovations if you need additional guides or manuals and have not received them.

Product names mentioned herein may be trademarks (™) and/or registered trademarks (®) of their respective companies, which may include Power Innovations International, Inc. (part of LITEON Group), LITEON Technology Corporation, or a third party.

**Copyright © 2026**

Power Innovations International, Inc.; American Fork, UT, USA

*All rights reserved.*

# Contents

---

<b>1— Product Overview .....</b>	<b>1</b>
1.1 Introduction .....	1
1.2 What’s Provided with the Charger .....	1
1.3 Features and Benefits.....	1
1.4 Charger Features Identified.....	2
1.5 Symbols Used in this Manual .....	3
1.6 Acronyms Used in this Manual .....	3
<b>2— Safety and Specifications .....</b>	<b>4</b>
2.1 IMPORTANT SAFETY INSTRUCTIONS – SAVE THESE INSTRUCTIONS .....	4
2.2 Specifications - Model EVPC3082, 30 kW EV Charger with 82 kWh Battery .....	5
<b>3— Securing EVPC3082 EV Charger with Battery into Vehicle.....</b>	<b>6</b>
3.1 Become Familiar with Charger Dimensions and Best Practices for Operation .....	6
3.2 Secure Battery EV Charger to Vehicle .....	7
<b>4— Operating EVPC3082, 30 kW EV Charger with 82 kWh Battery .....</b>	<b>9</b>
4.1 Turn Off EVPC3082 Charger.....	10
4.2 Charge an Electric Vehicle (EV) using CCS1 Charging Cable.....	11
4.3 Re-charge EVPC3082 Charger’s Battery using a Level 2 EV Charger.....	13
4.4 Re-charge EVPC3082 Charger’s Battery using a 240 Vac Power Source .....	15
4.5 Operate Emergency Stop .....	17
<b>5— Maintaining EVPC3082, 30 kW EV Charger with 82 kWh Battery .....</b>	<b>18</b>
5.1 Restart after Emergency Stop .....	18
5.2 Install Power Supply Units and Shelf Controllers .....	19
<b>6— Warranty .....</b>	<b>21</b>
<b>7— Contact Information .....</b>	<b>22</b>

This page left blank intentionally.

# 1—Product Overview

This section provides a product overview for Power Innovations International’s 30 kW DC EV Charger with 82 kWh Battery, Model EVPC3082.

## 1.1 Introduction

The EVPC3082 is an all-in-one, mobile DC quick charger with integrated 82 kWh battery making charging electric vehicles faster and easier, particularly when stationary installations are out of range or not available. The integrated battery storage offers a truly mobile charging solution that can be re-charged from common utility voltages. This product is capable of fitting in standard ¾ ton pickup trucks or cargo/delivery vans. Applications may include:

- Rental car facilities
- Festivals, live events, & movie sets
- EV infrastructure & service providers
- Emergency charging
- Retail & hospitality
- OEM test facilities
- Municipalities
- Small, mid, and large fleets & depots

All of Power Innovations International’s EV chargers have industry standard connectivity for fast charging, remote services and software updates. Once installed and operational, an operator can plug the EV charging cable into an electric vehicle, use an RFID card for authorization, and start a charging session.

Use this document to help you:

1. Become familiar with charger’s features, safety and installation requirements, and charger specifications.
2. Complete full initial battery charge.
3. Charge an electric vehicle at power up to 30 kW.
4. Recharge battery using L2 charger at power up to 12 kW.
5. Recharge battery using 240 Vac at power up to 12 kW.
6. Maintain charger, including replacing Power Supply Units and Shelf Controllers, and configuring the cellular modem.

## 1.2 What’s Provided with the Charger

P/N	Description
EVPC3082	30 kW EV Charger with 82 kWh Battery, fully assembled
MNL223	Manual: “30 kW EV Charger with 82 kWh Battery, Model EVPC3082, Operation Manual”

## 1.3 Features and Benefits

- Truly mobile and portable DC fast charging solution
- Integrated high-capacity battery for off-grid applications
- Recharging from commonly available grid voltages
- Field-replaceable power modules and shelf controllers
- Greater than 1 million hours MTBF on PSU topology
- IP54/NEMA 3S system enclosure
- Remote upgrades via over-the-air updates



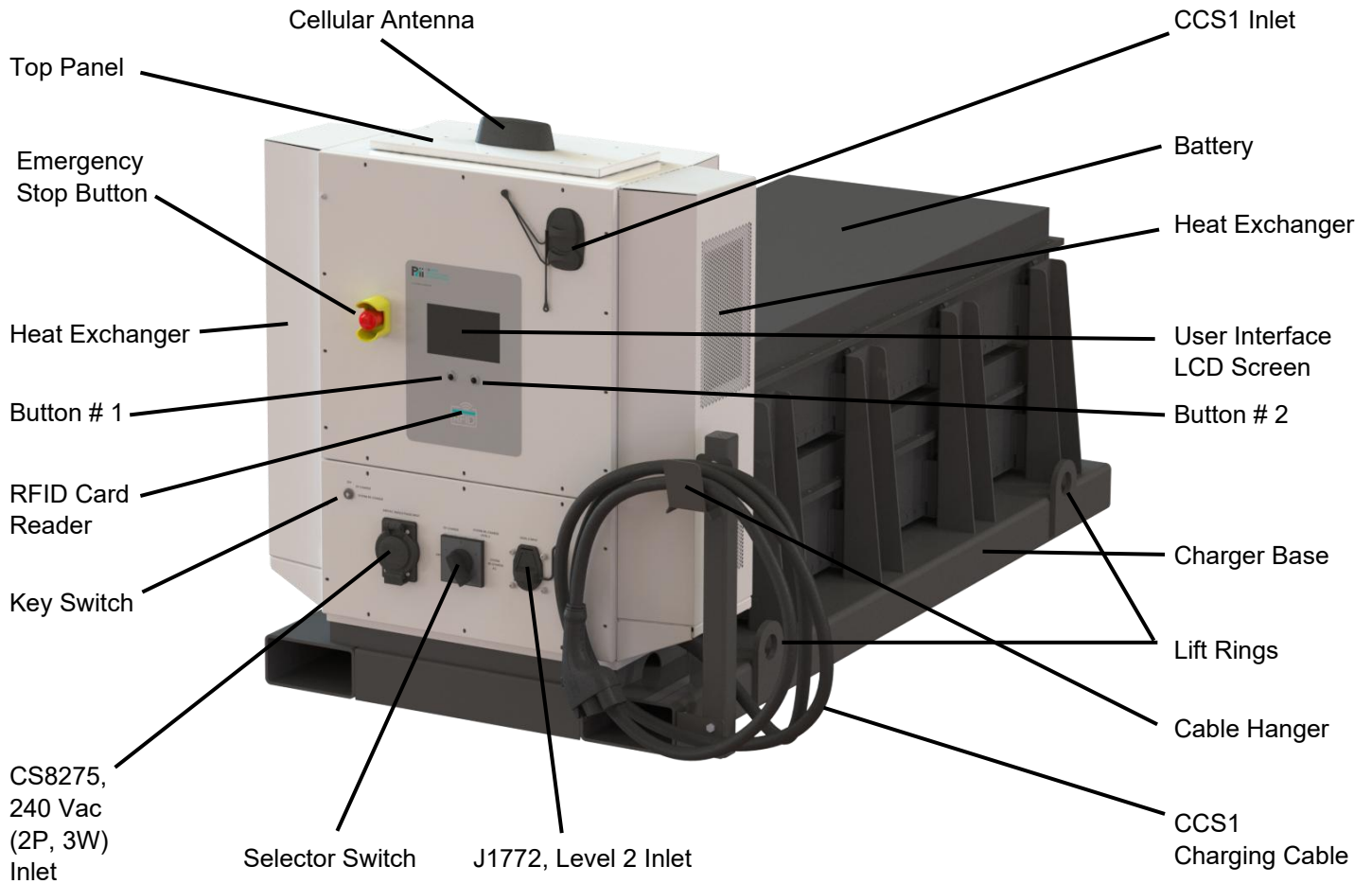

## 1.4 Charger Features Identified



**Figure 1—30 kW EV Charger with 82 kWh Battery, Model EVQC030-3xxx**

## 1.5 Symbols Used in this Manual

Icons or symbols are occasionally used throughout this manual to help identify safety warnings and other pertinent content contained here. These icons are described in the table below.

<i>Icon</i>	<i>Type of Warning</i>	<i>Description</i>
	<b>ELECTRICAL WARNING!</b>	<b>WARNING! RISK OF ELECTRIC SHOCK!</b> ADDITIONAL TEXT THAT FOLLOWS THIS SYMBOL PROVIDES MORE INFORMATION ABOUT THE SPECIFIC WARNING.
	<b>WARNING!</b>	<b>WARNING!</b> ADDITIONAL TEXT THAT FOLLOWS THIS SYMBOL PROVIDES MORE INFORMATION ABOUT THE SPECIFIC WARNING.
	<b>CAUTION!</b>	<b>CAUTION!</b> Indicates a potentially hazardous situation which, if not avoided, can result in minor to moderate injury, or serious damage to the equipment. Important safety measures may also be described in Cautions.
	<b>Note</b>	<b>Note</b> Offers practical advice that may be helpful but can be disregarded.

## 1.6 Acronyms Used in this Manual

<i>Acronym</i>	<i>Explanation</i>
AC	Alternating Current
DC	Direct Current
EV	Electric Vehicle
PSU	Power Supply Unit (described in Section 3.7)
SC	Shelf Controller (described in Section 3.7)

## 2—Safety and Specifications

---

The following safety instructions apply throughout EV Charger operation and maintenance. Be familiar with them before moving on to the next section to complete the installation.

### 2.1 IMPORTANT SAFETY INSTRUCTIONS – SAVE THESE INSTRUCTIONS

#### INSTRUCTIONS IMPORTANTES CONCERNANT LA SÉCURITÉ CONSERVER CES INSTRUCTIONS



##### **ELECTRICAL WARNINGS – WARNING! RISK OF ELECTRIC SHOCK!**

##### **WARNING! RISK OF ELECTRIC SHOCK!**

**ONLY QUALIFIED ELECTRICAL PERSONNEL FAMILIAR WITH THE CONSTRUCTION AND OPERATION OF THIS TYPE OF EQUIPMENT AND THE HAZARDS INVOLVED SHOULD ADJUST, MODIFY, AND SERVICE THIS EQUIPMENT. FAILURE TO OBSERVE THIS PRECAUTION COULD RESULT IN SEVERE INJURY OR DEATH.**

##### **WARNING! RISK OF ELECTRIC SHOCK!**

**READ THIS MANUAL THOROUGHLY PRIOR TO ENERGIZING THE EQUIPMENT. INSPECTION AND MAINTENANCE OF THIS EQUIPMENT SHOULD BE PERFORMED IN ACCORDANCE WITH THE PROCEDURES DETAILED IN THIS MANUAL.**

##### **WARNING! RISK OF ELECTRIC SHOCK!**

**THIS UNIT CONTAINS NO INTERIOR PARTS THAT CAN BE SERVICED WITHOUT QUALIFIED PERSONNEL. IF MAINTENANCE PROCESSES SPECIFIED IN THIS MANUAL FAIL TO SOLVE THE PROBLEM, QUALIFIED PERSONNEL MUST SERVICE THE UNIT.**

##### **WARNING! RISK OF ELECTRIC SHOCK!**

**THE PURPOSE OF THIS MANUAL IS TO PROVIDE YOU WITH INFORMATION NECESSARY TO SAFELY OPERATE AND MAINTAIN THIS EQUIPMENT. KEEP THIS MANUAL FOR FUTURE REFERENCE.**

##### **WARNING! RISK OF ELECTRIC SHOCK!**

**SHUT OFF POWER SUPPLY BEFORE BEGINNING MAINTENANCE WORK. FAILURE TO OBSERVE THIS PRECAUTION COULD RESULT IN SEVERE INJURY OR DEATH.**

##### **WARNING! RISK OF ELECTRIC SHOCK!**

**THIS EV QUICK CHARGER CONTAINS HIGH VOLTAGE POWER THAT IS POTENTIALLY DANGEROUS IF NOT HANDLED PROPERLY.**



**CAUTION! The user is responsible for conforming to all local and national electrical codes and standards applicable in the jurisdiction this equipment is operated in, including providing suitable wire sizes per NEC for input charging.**

## 2.2 Specifications - Model EVPC3082, 30 kW EV Charger with 82 kWh Battery

<b>Electrical Specifications</b>	
<b>AC Input</b>	
AC Input Power Options	240 V single phase Level 2 EV charger
AC Input Current	240 V single phase: 50 A max Level 2 EV charger: 48 A max
Recommended upstream overcurrent protection device rating	50 A
Power factor	> 0.98
Efficiency	> 95% @ full load
<b>DC Output</b>	
Maximum DC Output Power	30 kW
DC Output Voltage Range	250 V – 920 V
Maximum DC Output Current	80 A with DC output < 450V 40 A with DC output > 450V
DC Output Connector	CCS1 or NACS
DC Charging Cable Length	5 m (16.4 ft.) standard
<b>Battery Packs</b>	
Battery Chemistry	Lithium Iron Phosphate (LFP)
Cycle Life	3000 Cycles (80% of original capacity)
Rated Input Power	12 kW from 240 Vac or Level 2
Input Charging Connectors	CS8275 Inlet for 240 Vac single phase J1772 Inlet for Level 2 Charger
<b>Dimensions, Weights, and Network Interface</b>	
Dimensions (W x D x H) – with Cable Hanger	41" x 81" x 44.5" (1040 mm x 2056 mm x 1130 mm)
Weight – Charger with Battery on base	885 kg (1950 lbs.)
Network Interface	Cellular 4G LTE, Wi-Fi
<b>Environment Specification</b>	
Operating Temperature Range	-30°C to +50°C
Storage Temperature Range	-40°C to +80°C
Ingression Protection of Enclosure	IP54, NEMA 3S
Relative Humidity	95%
Altitude - Operation	2000 m (6560 ft.)

## 3—Securing EVPC3082 EV Charger with Battery into Vehicle



**ELECTRICAL WARNINGS – WARNING! RISK OF ELECTRIC SHOCK!**

**WARNING! RISK OF ELECTRIC SHOCK! DO NOT OPERATE CHARGER IN A HAZARDOUS LOCATION!**

**WARNING! RISK OF ELECTRIC SHOCK! ONLY QUALIFIED ELECTRICAL PERSONNEL FAMILIAR WITH THE CONSTRUCTION AND OPERATION OF THIS TYPE OF EQUIPMENT AND THE HAZARDS INVOLVED SHOULD ADJUST, MODIFY, AND SERVICE THIS EQUIPMENT. FAILURE TO OBSERVE THIS PRECAUTION COULD RESULT IN SEVERE INJURY OR DEATH.**

### 3.1 Become Familiar with Charger Dimensions and Best Practices for Operation

1. Become familiar with essential dimensions of the 30 kW EV Charger with 82 kWh Battery:  
Product Dimensions provided in Figure 2 are displayed in bracketed millimeters [mm] above and inches below.

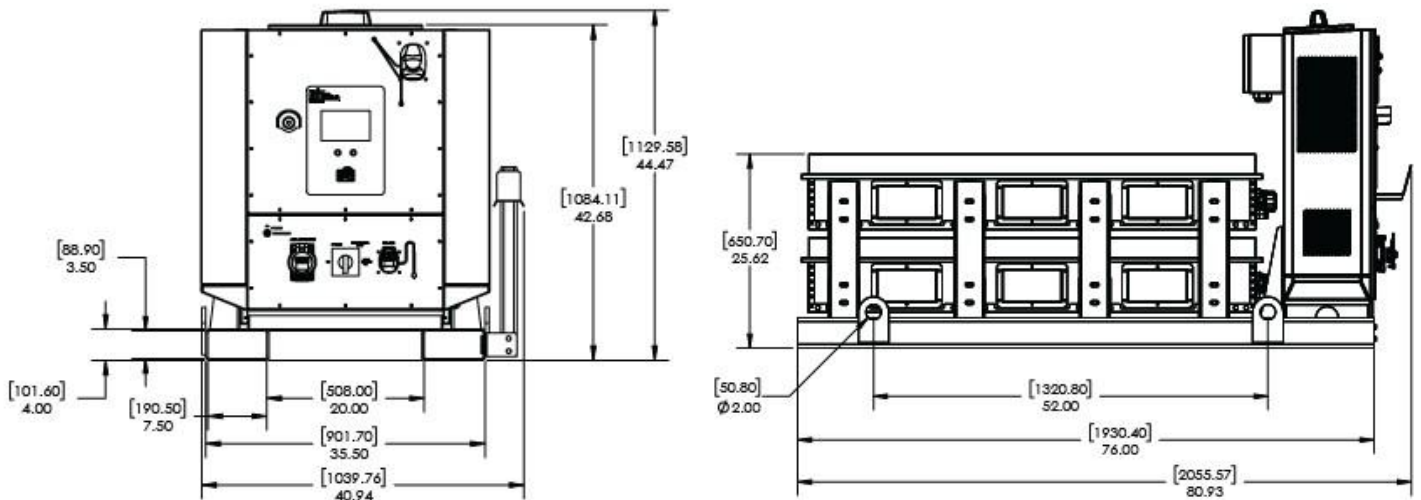

**Figure 2—Height, Width, and Depth dimensions of 30 kW EV Charger with 82 kWh Battery, Model EVPC3082**

2. Do not operate or plan to operate the charger in a hazardous location.



**ELECTRICAL WARNING - WARNING! RISK OF ELECTRIC SHOCK!**

**DO NOT INSTALL OR PLAN TO INSTALL CHARGER IN A HAZARDOUS LOCATION!**

3. Best practices for charger's operation locations:
  - a. Select location where charger will not be in direct sunlight.

### 3.2 Secure Battery EV Charger to Vehicle



**WARNING! FAILURE TO PROPERLY SECURE THIS EQUIPMENT CAN RESULT IN SERIOUS INJURY, DEATH, OR PROPERTY DAMAGE. YOU ARE SOLELY RESPONSIBLE FOR ENSURING THE LOAD COMPLIES WITH ALL APPLICABLE FEDERAL, STATE, AND LOCAL REGULATIONS.**



**CAUTION!** –This Battery EV Charger weighs 885 kg (1950 lbs.), fully loaded with power supply units (PSUs) and shelf controllers (SCs). To help avoid injury, use a crane or forklift, eye bolts and straps, AND other lift supports when lifting and placing this charger with battery into a vehicle (such as a truck bed or trailer).

Before attempting to lift or secure the Battery EV Charger, review all requirements listed in the following table, “*CARGO SECUREMENT – LEGAL AND SAFETY REQUIREMENTS*,” and comply with all listed requirements as well as any additional state or local regulations.

**CARGO SECUREMENT – LEGAL AND SAFETY REQUIREMENTS**



**WARNING! FAILURE TO PROPERLY SECURE THIS EQUIPMENT CAN RESULT IN SERIOUS INJURY, DEATH, OR PROPERTY DAMAGE. YOU ARE SOLELY RESPONSIBLE FOR ENSURING THE LOAD COMPLIES WITH ALL APPLICABLE FEDERAL, STATE, AND LOCAL REGULATIONS.**

**Minimum Performance Requirement (U.S. FMCSA / North American Cargo Securement Standard)**

The combined Working Load Limit (WLL) of all tiedowns must equal or exceed **50% of the charger’s weight.**

Charger Weight	Minimum Total WLL Required
1950 lb.	975 lb.

**Approved Tiedown Points**

Use the four (4) corner lift eyes/rings or the forklift pockets.  
**Never route straps or chains over the top of the batteries, charger, or any other components.**

**Acceptable Tiedown Devices**

- Use only devices permanently marked with Working Load Limit (WLL):
- Grade 70, 80, or 100 transport chain.
  - Synthetic web assemblies (ratchet straps) with sewn-on WLL tag.
  - Steel strapping or wire rope marked FMCSA standards.



**WARNING! UNMARKED STRAPS, ROPE, BUNGEE CORDS, OR CARGO BARS DO NOT MEET LEGAL REQUIREMENTS AND MUST NOT BEEN USED AS PRIMARY SECUREMENT.**

**Minimum Number and Arrangement**

Secure the unit with no fewer than four (4) tiedowns, each attached to a separate vehicle anchor point and to one of the four corner lift eyes or through the forklift pockets:

- Route tiedowns in a cross-diagonal (X) or V-patter whenever possible.
- Maintain a tiedown angle between 30° and 60° from horizontal (45° is ideal). Angles flatter than 30° count only as 50% of marked WLL toward the 1,000 lb. minimum.
- All four tiedowns must collectively restrain the load forward, rearward, side-to-side, and upward.

**Additional Requirements**

- Use corner protectors or edge guards wherever webbing or chain contacts a sharp edge.
- On trailers, attach only to frame, stake pockets, or rated D-rings; never to rub rails or Wood decking alone.

**Inspection**

Inspect tension and condition of all tiedowns:

- Before driving.
- After the first 50 miles.
- Every 3 hours or 150 miles thereafter.

**Legal Note**

The above are minimum standards derived from U.S. FMCSA regulations (49 CFR §§393.100-393.136) and the North American Cargo Securement Standard. Some states, provinces, and countries require higher performance levels. When in doubt, use more or stronger tiedowns than specified here.

## 4—Operating EVPC3082, 30 kW EV Charger with 82 kWh Battery

EVPC3082 has 4 supported modes:

- OFF to power charger off.
- EV CHARGE to charge an Electric Vehicle using the attached CCS1 Charging Cable.
- SYSTEM RE-CHARGE LEVEL 2 to re-charge integrated battery using a J1772 Level 2 EV Charging Cable.
- SYSTEM RE-CHARGE AC to re-charge integrated battery using a CS8264C 240 Vac connector.

These modes are controlled by the Key Switch and Selector Switch, shown in Figure 3 and enlarged in Figures 4 and 5.

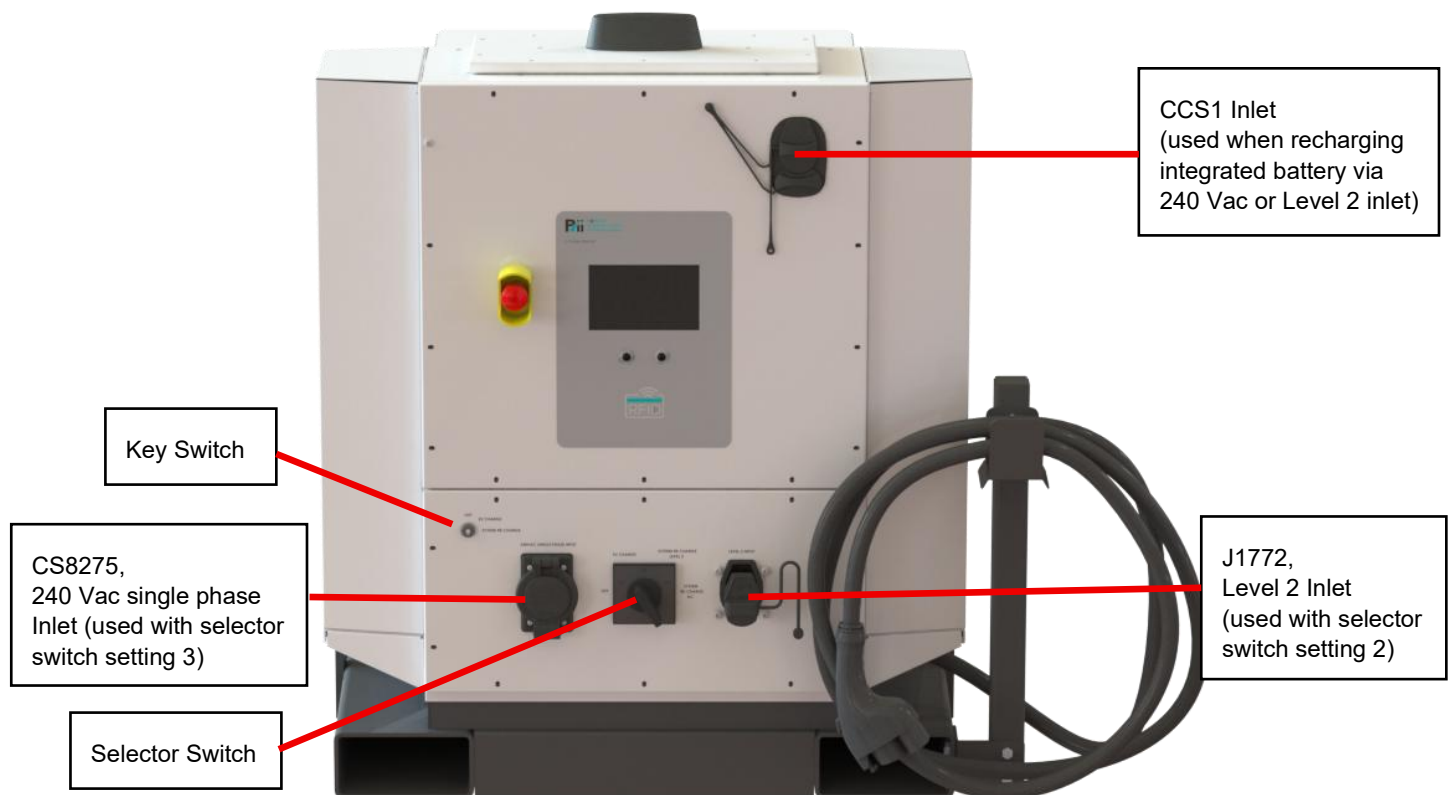
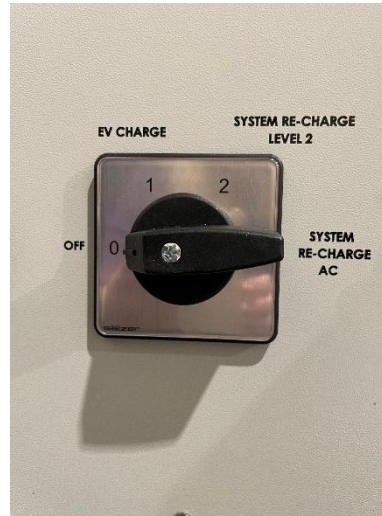

Figure 3—EVPC3082



**Figure 4 – Key Switch**



**Figure 5 – Selector Switch**

#### **4.1 Turn Off EVPC3082 Charger**

To turn off the charger:

1. Set Key Switch to the “OFF” Position
2. Set Selector Switch to the “OFF” Position.
3. It may take up to 2 minutes for the display to turn off once switches are set to the “OFF” (0) position.

**Figure 6—Key Switch  
in OFF position**

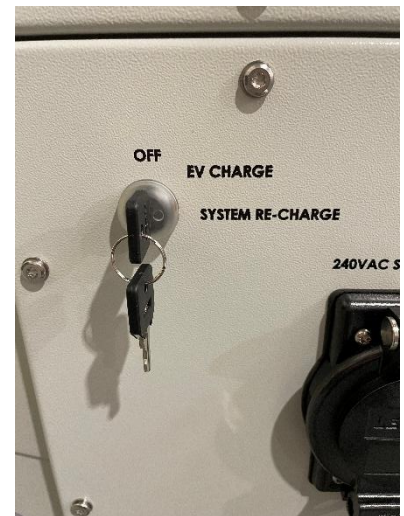

**Figure 7—Selector Switch  
in OFF (0) position**

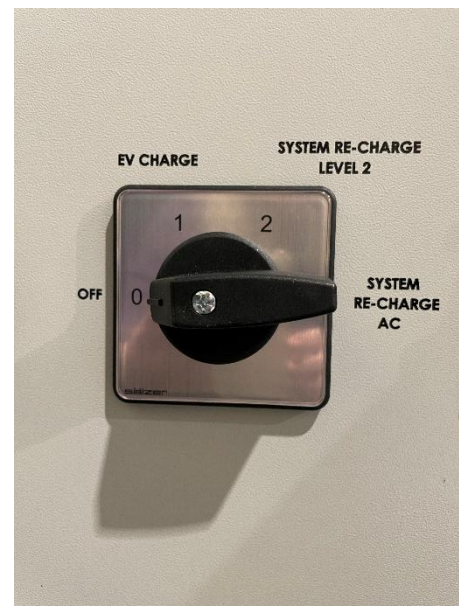

## 4.2 Charge an Electric Vehicle (EV) using CCS1 Charging Cable

To charge an electric vehicle (EV):

1. Set Key Switch to the “EV CHARGE” position.  
The display screen will turn on.



Figure 8—Key Switch in EV CHARGE position

2. Set Selector Switch to the “EV CHARGE” (1) position.

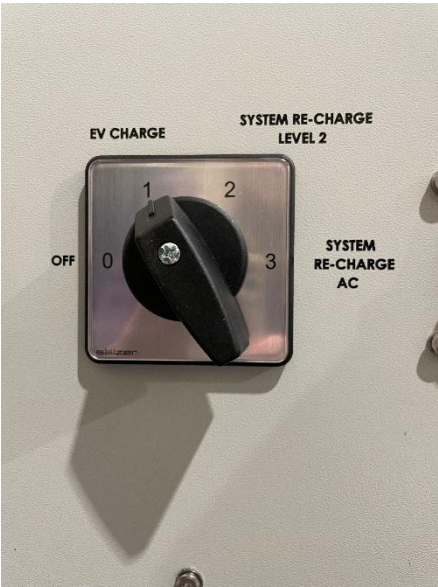
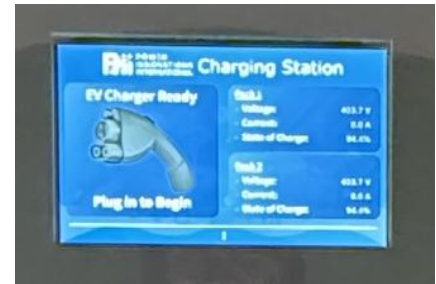

Figure 9—Selector Switch in EV CHARGE (1) position

**Note:** If Key Switch and Selector Switch do not align with the instructions above, you will not be able to charge an EV. Ensure the Key Switch and Selector Switch are aligned to proceed.

- The display screen will show a screen similar to the example shown here, with the left side of screen showing EV Charger status and instructions and the right side of screen showing Battery Pack 1 and Pack 2 status.
- Remove CCS1 charging cable from cable hanger and plug into an EV.
- Watch display for authorization.



- Follow on-screen displays to ensure EV charger connects to vehicle and the EV charging cycle begins. Once charging cycle successfully starts, the charging progress displays.



- The EV charger will automatically complete the EV charging cycle if left undisturbed. If you wish to stop charging early, press either Button # 1 or Button # 2 (shown in Figure 1). When the charging cycle ends or is stopped, the following prompt displays.



- Click to release CCS1 cable from EV and return it to cable hanger.

### 4.3 Re-charge EVPC3082 Charger’s Battery using a Level 2 EV Charger

To charge the system’s battery from a Level 2 Charger:

1. Set Key Switch to the “SYSTEM RE-CHARGE” position. The display screen will turn on.

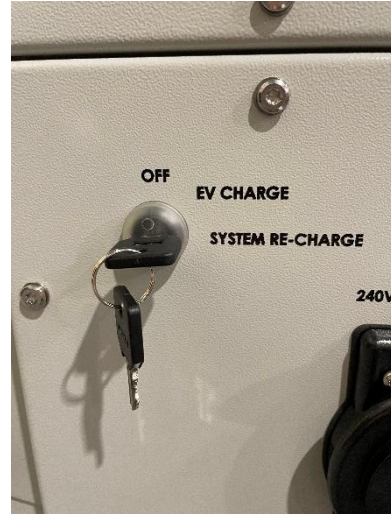

**Figure 10—Key Switch in SYSTEM RE-CHARGE position**

2. Set Selector Switch to the “SYSTEM RE-CHARGE LEVEL 2” (2) position.

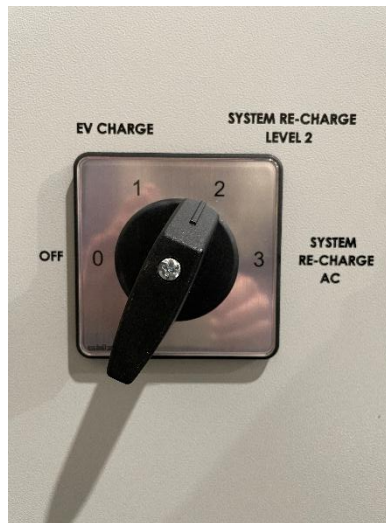

**Figure 11—Selector Switch in SYSTEM RE-CHARGE LEVEL 2 (2) position**



**Note:** If Key Switch and Selector Switch do not align with the instructions above, you will not be able to re-charge the battery. Ensure the Key Switch and Selector Switch are aligned to proceed.

3. Charger’s display screen will show a screen similar to the example shown here, with left side of screen showing EV Charger status and instruction and right side of screen showing Battery Pack 1 and Pack 2 status.



4. On the front of the charger, remove the Level 2 Inlet cover and plug a J1772 Level 2 EV charging cable into the J1772 Level 2 inlet (Figure 12).



**Note:** Maximum charging current via Level 2 inlet is 48 A.



**Figure 12—Level 2 Inlet cover being removed and Level 2 EV charger's output cable handle plugged into EVPC3082 Charger's Level 2 Inlet**

5. Plug the charger's CCS1 cable into its CCS1 inlet (shown below).

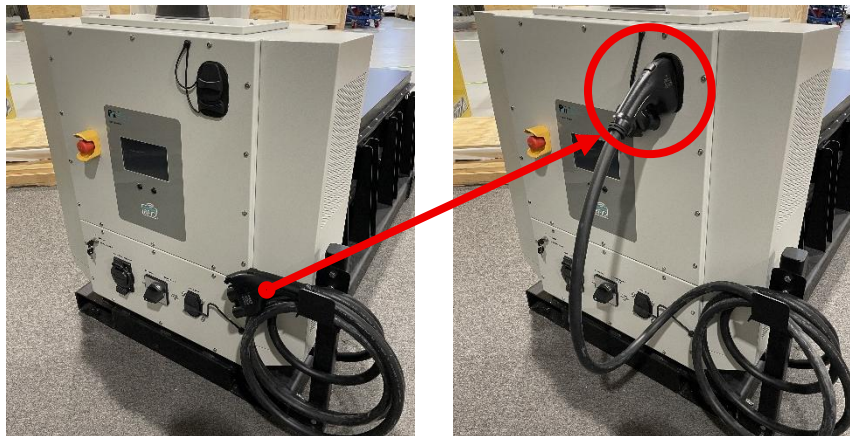

**Figure 13—CCS1 cable on cable hanger and after plugging CCS1 cable into CCS1 Inlet**

6. Charger's display will show a screen similar to the one shown here once re-charging begins:
7. If you wish to stop re-charging cycle early, or once re-charging cycle has completed:
  - 7.1 Click the CCS1 charging cable handle to release it from the CCS1 inlet and return the cable to the cable hanger.
  - 7.2 Press Level 2 cable handle button to release it from Level 2 input port.
  - 7.3 Follow instructions in Section 4.2 to re-enter EV Charge mode or Section 4.1 to turn OFF the charger.



**Note:** If the Level 2 cable is disconnected before the CCS1 cable, you may have to power cycle the EVPC3082 charger. To do this: (1) Set Key Switch to the "OFF" position and Selector Switch to the "OFF" position. (2) Follow instructions to once again use this charger to enter EV Charge mode or System Re-Charge mode.

### 4.4 Re-charge EVPC3082 Charger’s Battery using a 240 Vac Power Source

To re-charge the system’s battery from a 240 Vac input:

- 1. Set Key Switch to the “SYSTEM RE-CHARGE” position. The display will turn on.

Figure 14—Key Switch in SYSTEM RE-CHARGE position



- 2. Set Selector Switch to the “SYSTEM RE-CHARGE AC” (3) position.

Figure 15—Selector Switch in SYSTEM RE-CHARGE AC (3) position

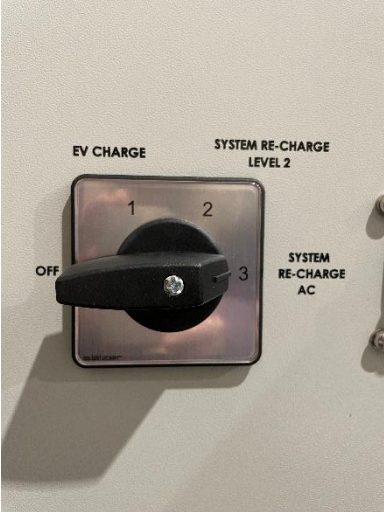

**Note:** If Key Switch and Selector Switch do not align with the instructions above, you will not be able to recharge the battery. Ensure the Key Switch and Selector Switch are aligned to proceed.

- 3. Charger’s display screen will show a screen similar to the example shown here, with left side of screen showing EV Charger status and instruction and right side of screen showing Battery Pack 1 and Pack 2 status.



4. On the front of the charger, lift the 240 Vac inlet cover and then plug a CS8264C, 240 Vac plug into the 240 Vac inlet (Figure 16).

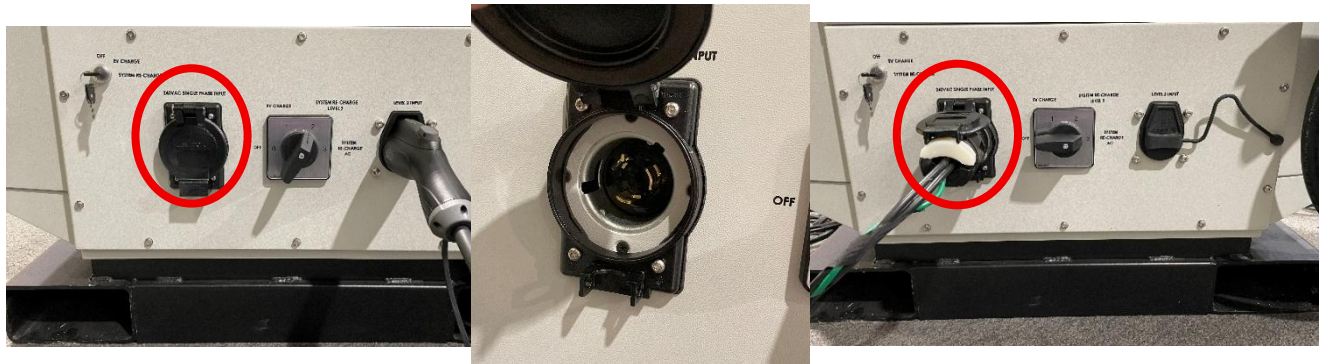

**Figure 16—240 Vac Inlet and 240 Vac power source plugged into 240 Vac Inlet**

5. Plug the charger's CCS1 cable into its CCS1 inlet (Figure 17).

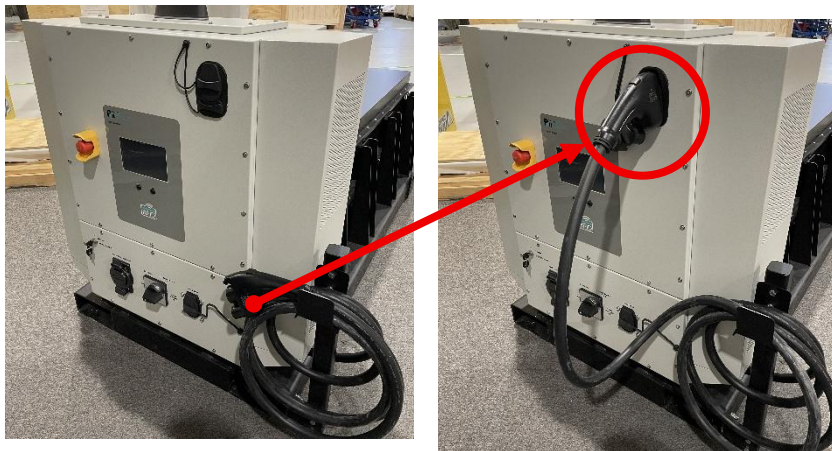

**Figure 17—CCS1 Cable on Hanger and plugged into CCS1 Inlet**

6. Charger's display will show the following screen once re-charging begins:
7. If you wish to stop re-charging cycle early, or once re-charging cycle has completed:

- 7.1 Click the CCS1 charging cable handle to release it from the CCS1 inlet and return the cable to the cable hanger.

- 7.2 Disconnect 240 Vac power cord from 240VAC inlet on the front of the charger.

- 7.3 Follow instructions in Section 4.2 to re-enter EV Charge mode or Section 4.1 to turn OFF the charger.

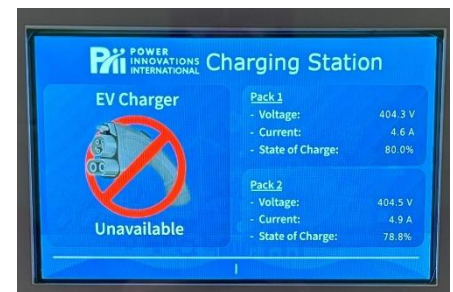

**Note:** If the 240 Vac plug is disconnected before the CCS1 charging cable is disconnected, you may have to power cycle the EVPC3082 charger. To do this, set Key Switch to the "OFF" position and Selector Switch to the "OFF" position. Then follow instructions to once again use this EVPC3082 charger to enter EV Charge mode or System Re-Charge mode.

## 4.5 Operate Emergency Stop

To operate the Emergency Stop:

1. In case of emergency, press the Red E-stop button located on the front of the EVPC3082 (Figure 18) to end any discharge or charge session.
2. After shutdown, pull the E-stop button out to reset it.



**Figure 18—Emergency Stop on the front of EVPC3082 Charger**

3. After the E-stop has been (1) pressed in and then (2) pulled out (to reset), you may have to power-cycle the charger to use the charger again. To power-cycle the charger:
  - 3.1 Set Key Switch to the “OFF” position.
  - 3.2 Set Selector Switch to the “OFF” (1) position.
4. To once again use the charger, follow the instructions in Section 4.2, 4.3, or 4.4 as needed:
  - 4.1 Section 4.2 – to use EV Charger mode to Charge an EV.
  - 4.2 Section 4.3 – to use System Re-Charge mode with a Level 2 EV Charger.
  - 4.3 Section 4.4 – to use System Re-Charge mode with a 240 Vac Power Source.

## 5—Maintaining EVPC3082, 30 kW EV Charger with 82 kWh Battery



**ELECTRICAL WARNING! - WARNING! RISK OF ELECTRIC SHOCK!**

**WARNING! RISK OF ELECTRIC SHOCK! SHUT OFF POWER SUPPLY AT AC BREAKER BEFORE BEGINNING MAINTENANCE ACTIVITIES AND BEFORE REMOVING EV QUICK CHARGER'S AC SERVICE PANEL FOR ANY MAINTENANCE WORK. FAILURE TO OBSERVE THIS PRECAUTION COULD RESULT IN SEVERE INJURY OR DEATH.**

**WARNING! RISK OF ELECTRIC SHOCK! THIS EV CHARGER AND CHARGING CABLE ARE ENERGIZED. BEFORE SERVICING THE CHARGER OR CABLE, SHUT OFF POWER SUPPLY TO CHARGER, CLICK HANDLE TO RELEASE CABLE PLUG FROM EV, AND RETURN CABLE PLUG TO THE DOCKING STATION.**



**CAUTION! Maintenance tasks should only be completed as directed in this section. When in doubt, contact Power Innovations on how to proceed.**

**AVERTISSEMENT ÉLECTRIQUE ! - AVERTISSEMENT ! RISQUE DE CHOC ÉLECTRIQUE !**

**ATTENTION ! RISQUE DE CHOC ÉLECTRIQUE ! ÉTEIGNEZ L'ALIMENTATION ÉLECTRIQUE AU DISJONCTEUR À COURANT ALTERNATIF AVANT DE COMMENCER LES ACTIVITÉS DE MAINTENANCE ET AVANT DE RETIRER LE PANNEAU D'ENTRETIEN CA DU CHARGEUR RAPIDE POUR VE POUR TOUT TRAVAIL DE MAINTENANCE. LE NON-RESPECT DE CETTE PRÉCAUTION POURRAIT ENTRAÎNER DES BLESSURES GRAVES OU LA MORT.**

**ATTENTION ! RISQUE DE CHOC ÉLECTRIQUE ! CE CHARGEUR DE VE ET CE CÂBLE DE CHARGE SONT SOUS TENSION. AVANT D'ENTREtenir LE CHARGEUR OU LE CÂBLE, COUPEZ L'ALIMENTATION DU CHARGEUR, CLIQUEZ SUR POIGNÉE POUR LIBÉRER LA PRISE DE CÂBLE DE L'EV ET RETOURNEZ LA PRISE DE CÂBLE À LA STATION D'ACCUEIL.**

**ATTENTION ! Les tâches d'entretien ne doivent être effectuées que conformément aux directives de la présente section. En cas de doute, contactez Power Innovations sur la façon de procéder.**

### 5.1 Restart after Emergency Stop



Any time the Emergency Stop button is pushed, it stays pushed in until it is reset for the next charging session. To reset the Emergency Stop button, simply pull the button out.

If the Emergency Stop button is pushed during a charging session, charging is stopped, an Error Message displays on the LCD screen (see Figure 34).



Before a new charging session can be started following this Error Message:

1. Charging cable must be unplugged from EV.
2. Emergency Stop button must be reset (pulled out).



**Note:** Resetting the button does not start a new charging session, but it prepares the charger to support the next charging session started.

## 5.2 Install Power Supply Units and Shelf Controllers



**ELECTRICAL WARNINGS – WARNING! RISK OF ELECTRIC SHOCK!**

**WARNING! RISK OF ELECTRIC SHOCK!**

**ENSURE POWER SUPPLY IS SHUT OFF BEFORE STARTING OR CONTINUING INSTALLATION ACTIVITIES AND BEFORE OPENING EV QUICK CHARGER’S TOP PANEL. FAILURE TO OBSERVE THIS PRECAUTION COULD RESULT IN SEVERE INJURY OR DEATH.**

To install shelf controllers (SCs) and power supply units (PSUs):

1. Open the charger’s Top Panel (Figure 19) by removing screws around perimeter using a T25 Torx t-handle screwdriver.
2. If necessary, temporarily disconnect cables from modem that tether top panel to modem and then set top panel and screws aside.



*Figure 19—Remove screws around Top Panel to open*

3. Insert 3 Shelf Controllers (SCs), 1 on each shelf in the slot provided (Figure 20).

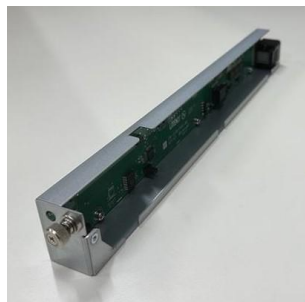

*Figure 20—Install each Shelf Controller into a Shelf Controller Slot*



- Secure each SC with its built-in screw to hand tight (Figure 21).

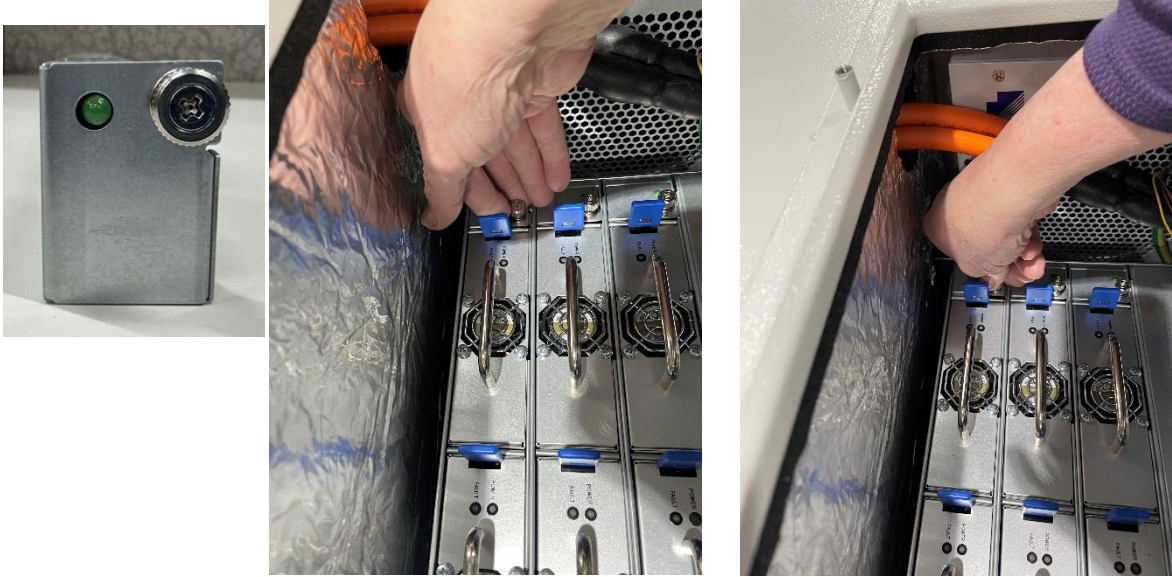

**Figure 21—Secure each Shelf Controller in its slot by pressing down on and hand-tightening built-in screw**

- Insert 9 power supply units (PSUs), 3 on each shelf (Figure 22), so that locking tab side of each PSU is closer to its shelf controller than the PSU's other side AND so each locking tab clicks into the locked position.
- If modem cables were temporarily disconnected in step 2, reconnect cables to modem before continuing.
- Return Top Panel to top of charger and secure with its original screws using T25 Torx t-handle screwdriver.

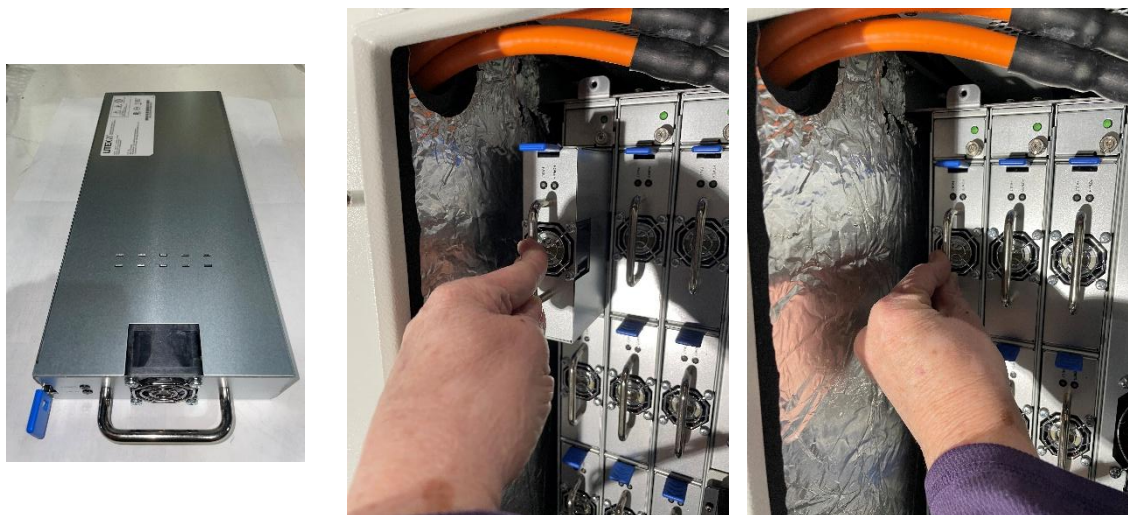

**Figure 22— Install Power Supply Units with Locking Tabs closer to Shelf Controllers**

## 6—Warranty

---

Power Innovations International warrants that products purchased hereunder are free and clear of all liens and encumbrances.

Power Innovations International warrants that products are to be free from material or workmanship defect under normal use for a period of two (2) years from the invoice date.

If any defect is found under normal usage conditions during the above warranty period, Power Innovations International will be responsible for repair or replacement at its sole discretion and subject to the replacement may be refurbished products.

All repair covered by this warranty must be done at Power Innovations International factory, or other repair facilities as designated by Power Innovations International unless Power Innovations International specifically directs that this service be performed at another location or service provider.

Customer shall, at its own costs, be responsible for shipping the defective products to the designated repair facilities subject to a RMA issued by Power Innovations International.

Power Innovations International will be responsible for shipping the repaired or refurbished unit back to the customer.

Power Innovations International shall not have any warranty obligations for claims: (i) caused by the misuse or abuse of products by end users; (ii) caused by modifications or repairs made to the products or disassembly of products by any person other than Power Innovations International, unless receiving Power Innovations International authorization; (iii) in relation to the appearance damage.

This Warranty Term states the exclusive liability of Power Innovations International and the exclusive remedy of buyer/customer with respect to any claim or defects of the products.

## 7—Contact Information

---

If there are any questions or comments about this product, please feel free to contact us.

**Power Innovations International, Inc.**

**Web:** [www.powerinnovations.com/support](http://www.powerinnovations.com/support)

**Phone:** 801-785-4123

**Mailing Address:** 1305 South 630 East, American Fork, UT 84003

**Copyright © 2026**

Power Innovations International, Inc. American Fork, UT, USA

*All rights reserved*